



Kit Contents			
	Description	Part No	Pcs
1	Spacer	24629-15	2
2.1	Shock absorber	BMS 1R40 (R)	1
2.2	Shock absorber	BMS 2R40 (L)	1
3	Dust boot	10216-01	2
4	Plastic spring spacer	25602-01	2
5	Spring		2
6	Rubber spring spacer	25601-01	2
7	Upper spring seat	25618-10	2
8	Spacer	24629-31	2
9	Washer	24619-03	2
10	Lock nut M12	24627-02	2
11	C-spanner	24639-03	1
12	C-spanner	24639-01	1
13	Öhlins sticker kit	10207-01	1
14	Öhlins emblem kit	10207-02	1
15	Öhlins Owners Manual		1

👁 Note!

Please note that this image is a general representation of the product and may differ slightly from your product.

👁 Note!

Please note that during storage and transportation, especially at high ambient temperature, some of the oil and grease used for assembling may leak and stain the packaging. This is in no way detrimental to the product, wipe off the excessive oil/grease with a cloth.

👁 Note!

Before installing this product, check the contents of the kit. If anything is missing, please contact an Öhlins dealer.

⚠ Warning!

Before installing this product, read the Öhlins Owner's Manual. The shock absorber is an important part of the vehicle and the vehicle stability.

Shock absorber Kit for BMW M2 (F87) – front

BMS MR40

Mounting Instructions



MOUNTING INSTRUCTIONS

⚠ Warning!

We strongly recommend to have an Öhlins dealer install this product.

⚠ Warning!

If working on a raised vehicle, ensure that it is securely supported to prevent it from tipping over.

👁 Note!

When working on this product, see the Vehicle Service Manual for vehicle specific procedures and important data.

1

Raise the vehicle and put it on jack stands.

⚠ Warning!

Ensure that it is securely supported.

2

Remove the front wheels.

3

Loosen the bolts for the lower strut attachments.

👉 Caution!

Support the wheel hubs in an appropriate way on each side of the vehicle so that the brake hoses can not be damaged.

4

Loosen the upper attachments and sway bar. Remove the original struts from the car.

5

Cut the dust boot 42 mm from the lower end with a pair of scissors according to fig 2.

6

Tighten the lower spring seat and the lock ring to 50 - 60 Nm according to fig 6.

Fit the dust boot (3), the spring (4), the upper spring seat (5), the spacer (6), the original top mount, the washer (7) and the M12 (8) to the shock absorber according to fig 1. Tighten the lock nut (8) to 35-40 Nm.

Figure 1

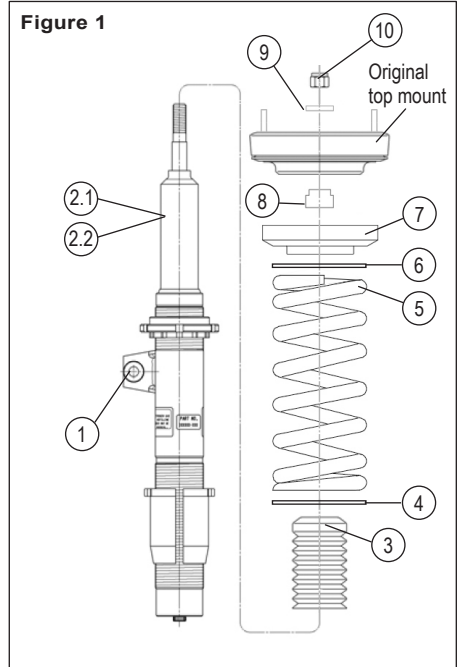
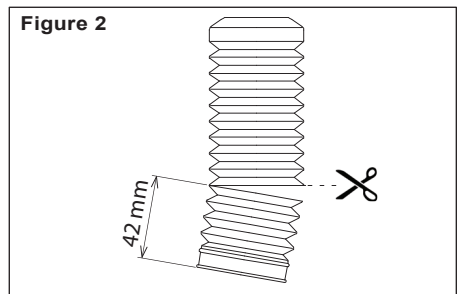

Figure 2



MOUNTING INSTRUCTIONS

7

Install the Öhlins McPherson struts on the vehicle according to fig 3.

Fit the stabilizer link according to fig 4.

BMS 1R40 = Right hand side

BMS 2R40 = Left hand side

8

Fasten the strut to the top mount of the vehicle.

Note!

When tightening the top mount nut, the shock absorber top pin must be held in position with a Allen key.

9

Raise the wheel hub with a jack to remove the freeplay of the lower strut attachment bolts before tightening them.

Note!

Make sure the Öhlins sticker on the strut is facing outwards and that the anti roll bar bracket clears the ABS cable bracket during full wheel turn.

Note!

Make sure that all bolts are tightened to the correct torque and that nothing fouls or restricts movement of the strut when it is being fully compressed or extended. Test this over the whole steering range from lock to lock

10

Make sure that all removed parts are reinstalled in the same way as they were before the installation of the Öhlins shock absorber.

Figure 3

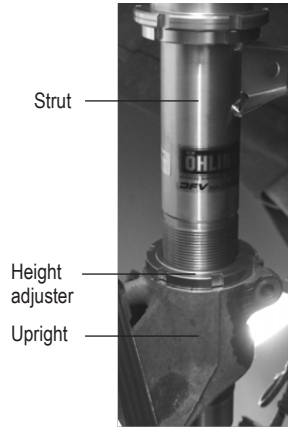
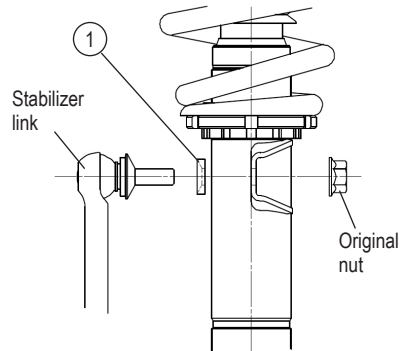

Figure 4



ADJUSTMENTS

⚠ Warning!

Before riding, always make sure that the basic settings made by Öhlins are according to recommended Set-up Data. Read about adjustments and setting up in the Öhlins Owner's Manual before you make any adjustments. Contact an Öhlins dealer if you have any questions about setting up.

The standard preload is 5 mm, see fig 6. Make sure to measure the length of the spring only.

SETUP DATA

Recommended set-up		
Setting adjustment		
Track	2-7	clicks
Winding road	5-10	clicks
Street	10-20	clicks
Spring preload	5	mm

Recommended spring

48010-27 (90 N/mm)

The actual vehicle height

With both the preload and height adjustments in their recommended positions, the vehicle is lowered approximately 10 mm when compared to the original suspension. As the height adjuster is turned one rotation, the position moves 1.5 mm.

Figure 6

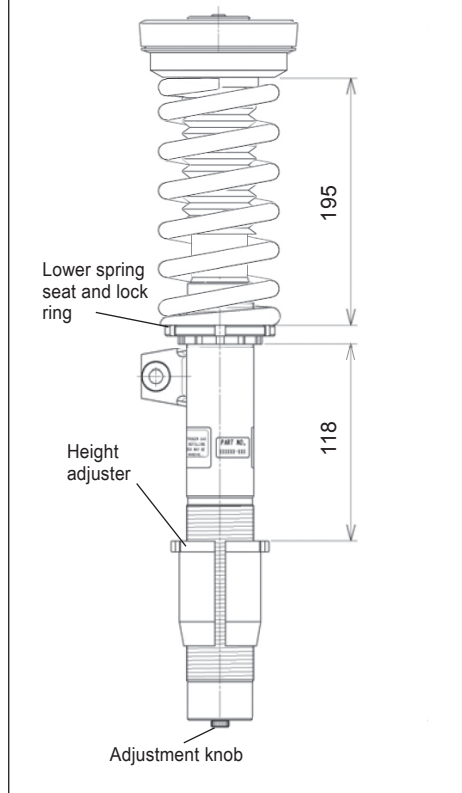

⚠ Warning!

The height adjuster range is the standard position ± 15 mm.

Öhlins products are subject to continuous improvement and development, therefore, although these instructions include the most up-to-date information available at the time of printing, minor updates may occur.

To find the latest information contact an Öhlins distributor. Please contact Öhlins if you have any questions regarding the contents in this document.

Part no. MI_BMSMR40_front_2
Issued 2017-09-12

© Öhlins Racing AB. All rights reserved. Any reprinting or unauthorized use without the written permission of Öhlins Racing AB is prohibited.

Öhlins Racing AB
Box 722
S-194 27 Upplands Väsby, Sweden
Phone +46 8 590 025 00
fax +46 8 590 025 80



www.ohlins.com



Kit Contents			
	Description	Part No	Pcs
1	Shock absorber	BMS 6R40	2
2	Bushing spacer	24629-32	4
3	Dust boot	10216-03	2
4	Rubber seat	25601-01	2
5	Spring preload adjuster	24651-02	2
6	Lock ring	24636-03	2
7	Spring seat	24635-03	2
8	Plastic spring spacer	25602-01	2
9	Spring		2
10	Plastic seat	25618-04	2

👁 Note!

Please note that this image is a general representation of the product and may differ slightly from your product.

👁 Note!

Please note that during storage and transportation, especially at high ambient temperature, some of the oil and grease used for assembling may leak and stain the packaging. This is in no way detrimental to the product, wipe off the excessive oil/grease with a cloth.

👁 Note!

Before installing this product, check the contents of the kit. If anything is missing, please contact an Öhlins dealer.

⚠ Warning!

Before installing this product, read the Öhlins Owner's Manual. The shock absorber/front fork/steering damper is an important part of the vehicle and the vehicle stability.

Shock absorber Kit for BMW M2 (F87) – rear

BMS MR40

Mounting Instructions



MOUNTING INSTRUCTIONS

⚠ Warning!

We strongly recommend to have an Öhlins dealer install this product.

⚠ Warning!

If working on a raised vehicle, ensure that it is securely supported to prevent it from tipping over.

👁 Note!

When working on this product, see the Vehicle Service Manual for vehicle specific procedures and important data.

1

Raise the vehicle and put it on jack stands.

⚠ Warning!

Ensure that it is securely supported.

2

Remove the rear wheels.

3

Remove the lower and the upper attachments and remove the original shock absorbers.

4

Remove the springs.

5

Set the spring seat of the spring preload adjuster to the position.

6

Remove the OEM upper spring cup according to figure 2.

7

Install the Öhlins spring and the spring preload adjuster on the vehicle.

8

Cut the dust boot according to fig 3.

Figure 1

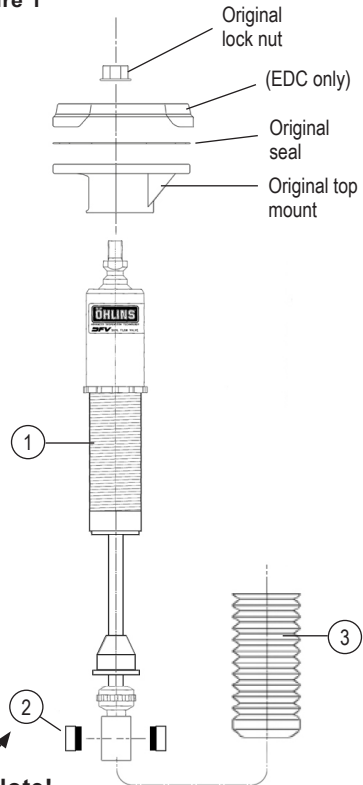

👁 Note!

Bushing spacer. Fit the spacers into the bushing.

Figure 2

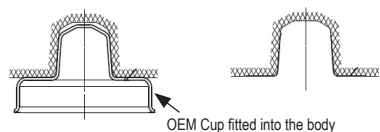

MOUNTING INSTRUCTIONS

9

Install the dust boot (3).

10

Tighten the lock ring (6) and spring seat (7) to 50-60 Nm. The original top mount assembly and tighten the original lock nut to 30 Nm.

11

Install the Öhlins shock absorbers on the vehicle.

12

Make sure that all removed parts are reinstalled in the same way as they were before the installation of the Öhlins shock absorber.

Note!

Make sure that all bolts are tightened to the correct torque and that nothing fouls or restricts movement of the shock absorber when it is being fully compressed or extended.

Figure 3

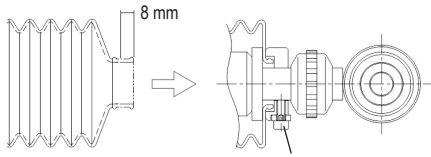
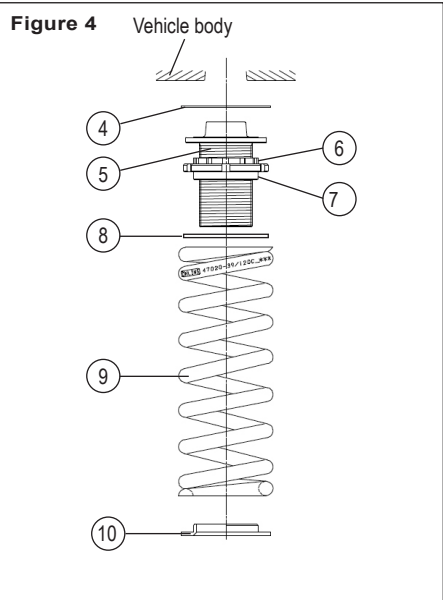

Figure 4



ADJUSTMENTS

⚠ Warning!

Before riding, always make sure that the basic settings made by Öhlins are according to recommended Set-up Data. Read about adjustments and setting up in the Öhlins Owner's Manual before you make any adjustments. Contact an Öhlins dealer if you have any questions about setting up.

SETUP DATA

Recommended set-up		
Setting adjustment		
Track	2-7	clicks
Winding road	5-10	clicks
Street	10-20	clicks
Spring preload adjuster height	40	mm
Shock absorber length	500	mm

Recommended spring

48010-67 (190 N/mm)

The actual vehicle height

With both the preload and height adjustments in their recommended positions, the vehicle is lowered approximately 10 mm when compared to the original suspension. As the height adjuster is turned one rotation, the position moves 1.5 mm.

⚠ Warning!

The adjustment range is the standard position ± 15 mm. If the bracket is moved outside the adjustment range, it may come loose.

Figure 5

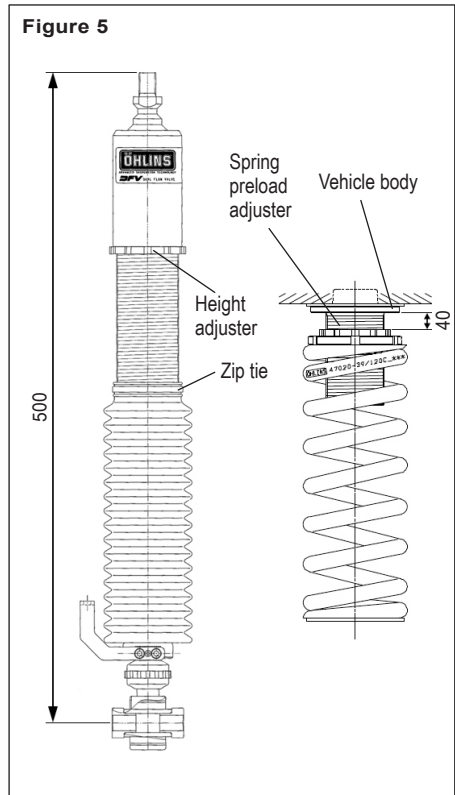

Öhlins products are subject to continuous improvement and development, therefore, although these instructions include the most up-to-date information available at the time of printing, minor updates may occur.

To find the latest information contact an Öhlins distributor. Please contact Öhlins if you have any questions regarding the contents in this document.

Part no. MI_BMSMR40_rear_2
Issued 2017-09-12

© Öhlins Racing AB. All rights reserved. Any reprinting or unauthorized use without the written permission of Öhlins Racing AB is prohibited.

Öhlins Racing AB
Box 722
S-194 27 Upplands Väsby, Sweden
Phone +46 8 590 025 00
fax +46 8 590 025 80



www.ohlins.com