

Adjustments

⚠ Warning!

Before driving, always make sure that the basic settings made by Öhlins are according to recommended Set-up Data. Read about adjustments and setting up in the Öhlins Owner's Manual before you make any adjustments. Contact an Öhlins dealer if you have any questions about setting up the shock absorber.

The standard preload is 15 mm from a free length of 200 mm, giving 185 mm installed length, see fig ③.

Set-up Data

Recommended set-up

Rebound 10 clicks
Spring preload 15 mm
Shock absorber length 421 mm

Spring

Spec H200, ID65, 50 N/mm

The actual vehicle height

With the height adjuster in their standard positions, the vehicle is lowered approximately 30 mm when compared to the original suspension. As the height adjuster is turned one rotation, the position moves 2.0 mm.

⚠ Warning!

The adjustment range is the standard position -3 to +15 mm.

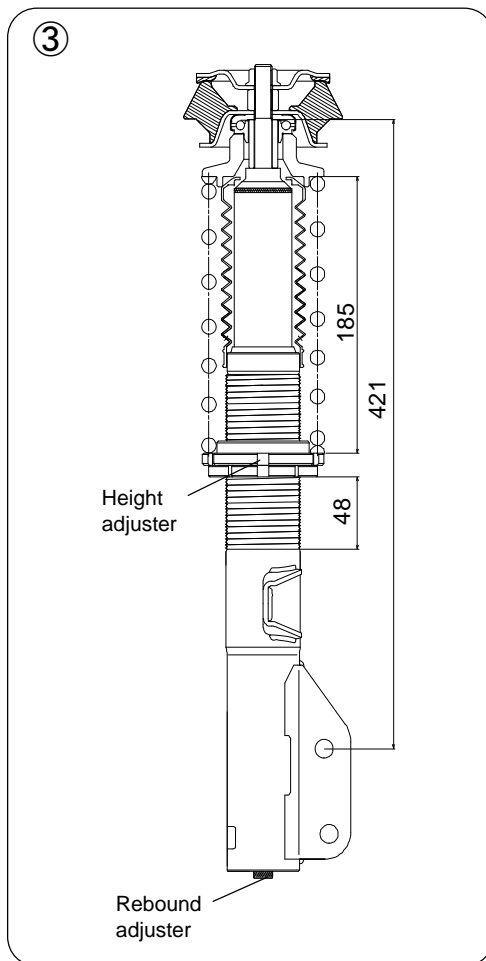

Before installing this product, check the contents of the kit. If anything is missing, please contact an Öhlins dealer.

Kit Contents	Pcs.
Shock absorber	2
Upper spring seat	2
Spacer	2
Dust boot	2
Spring	2
Washer	2
Nut M12	2
Nut M8	2
USED FOR BOTH FRONT AND REAR	1
C-spanner	1
C-spanner	1
Öhlins sticker	1
Öhlins Owner's Manual	1

Please note that during storage and transportation, especially at high ambient temperature, some of the oil and grease used for assembling may leak and stain the packaging. This is in no way detrimental to the product, wipe off the excess oil/grease with a cloth.

⚠ Warning!

Before installing this product, read the Öhlins Owner's Manual. The shock absorber is an important part of your vehicle and will affect the stability.

© Öhlins products are subject to continuous improvement and development, therefore, although these instructions include the most up-to-date information available at the time of printing, minor updates may occur.

To find the latest information contact your Öhlins distributor. Please consult your Öhlins dealer if you have any questions regarding the contents in this document.

Part no. SZSM100_0
Issued 2010-01-31

Öhlins Racing AB



www.ohlins.com

Shock Absorber Kit for Suzuki Swift-sports (ZC31S)

SZS M100 front

Mounting Instructions

© Öhlins Racing AB. All rights reserved. Any reprinting or unauthorized use without the written permission of Öhlins Racing AB is prohibited.



How to install

How to install

⚠ Warning!

It is advisable to have an Öhlins dealer install the shock absorber.

When installing, read your Vehicle Service Manual.



1
Raise the vehicle and put it on jack stands.

⚠ Warning!

Ensure that it is securely supported.

2
Remove the front wheels.

3
Remove the stabilizer links, the brake hoses and the ABS cords from the standard struts.

4
Loosen the bolts for the lower strut attachments.

⚠ Caution!

Support the wheel hubs in an appropriate way on each side of the vehicle so that the brake hoses can not be damaged.

5
Loosen the upper attachments. Remove the original struts from the car.

6
Tighten the lower spring seat and the lock nut to 50 - 60 Nm.
Fit the dust boot, the spacer, the spring and the upper spring seat to the strut according to fig ①.
Fit the standard lower bearing, the standard top mount, the standard rebound stopper and the nut M12. Tighten the top nut to 35 - 40 Nm.

7
Install the Öhlins McPherson struts on the vehicle.

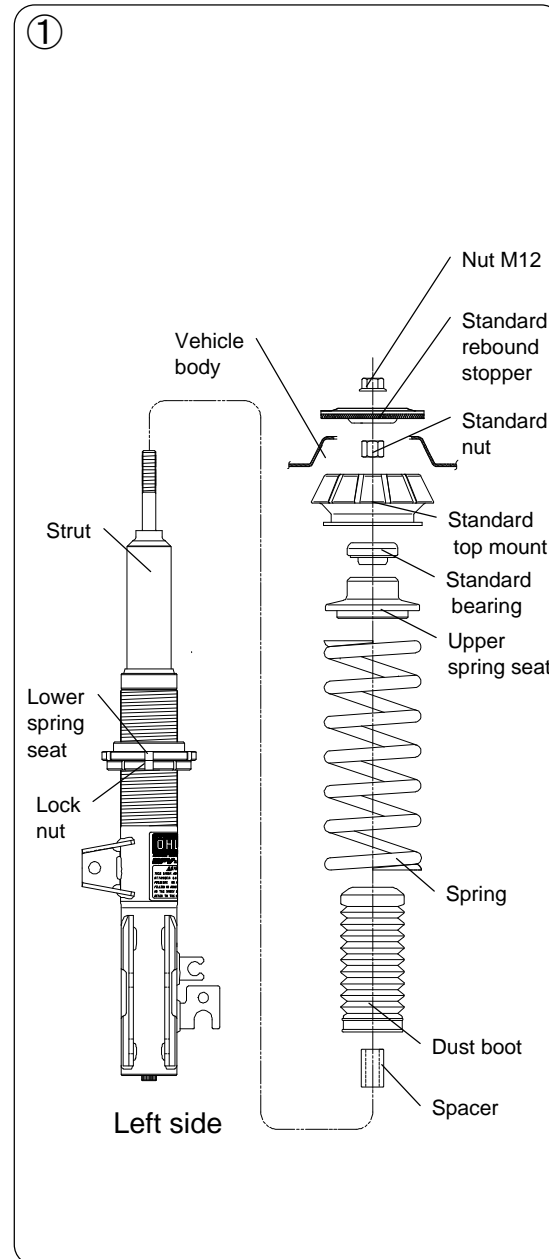

8

Mount the standard stabilizer links, the standard brake hose and the ABS cord, to the Öhlins struts according to fig ②.

👁 Note!

When tightening the top mount nut, the shock absorber shaft must be held in position with a 5 mm Allen key.

9

Fasten the upper attachments.

10

Raise the wheel hub with a jack to remove the freeplay of the lower strut attachment bolts before tightening them.

👁 Note!

Make sure that all bolts are tightened to the correct torque and that nothing fouls or restricts movement of the strut when it is being fully compressed or extended. Test this over the whole steering range from lock to lock.

11

Make sure that all removed parts are reinstalled in the same way as they were before the installation of the Öhlins shock absorber.

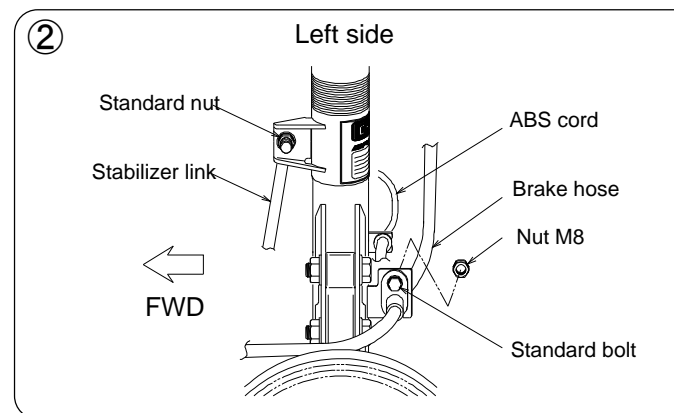

Adjustments

⚠ Warning!

Before driving, always make sure that the basic settings made by Öhlins are according to recommended Set-up Data. Read about adjustments and setting up in the Öhlins Owner's Manual before you make any adjustments. Contact an Öhlins dealer if you have any questions about setting up the shock absorber.

Set-up Data

Recommended set-up

Rebound 10 clicks

Shock absorber

length 541 mm

Spring

Spec H255, ID56-89, 22-44 N/mm

The actual vehicle height

The vehicle is lowered approximately 30 mm when compared to the original suspensor

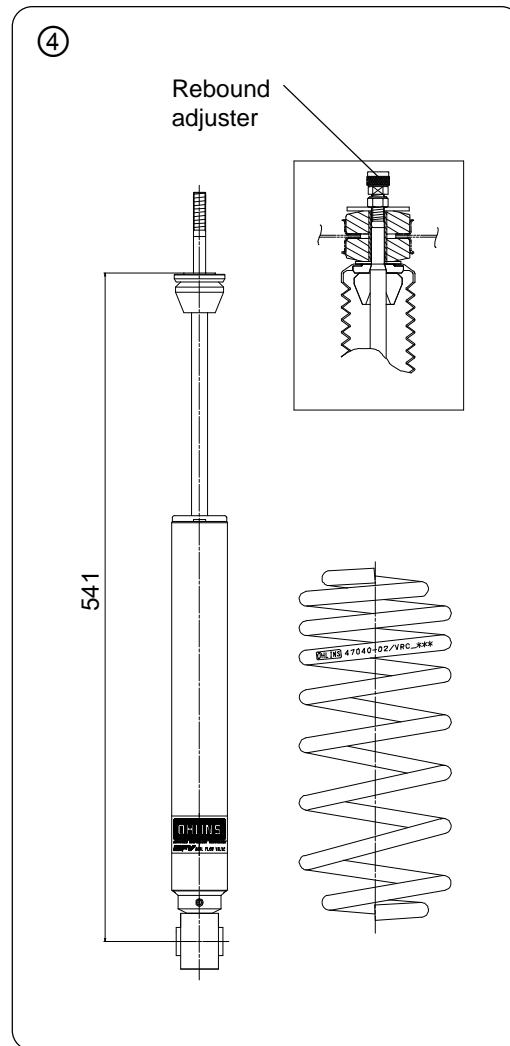

Before installing this product, check the contents of the kit. If anything is missing, please contact an Öhlins dealer.

Kit Contents	Pcs.
Shock absorber	2
Nylon nut M10	2
Dust boot	2
Spacer	2
Washer	2
Spring	2

MOUNTED ON SHOCK ABSORBER
Adjuster 1

USED FOR BOTH FRONT AND REAR

Öhlins sticker	1
Öhlins Owner's Manual	1

Please note that during storage and transportation, especially at high ambient temperature, some of the oil and grease used for assembling may leak and stain the packaging. This is in no way detrimental to the product, wipe off the excess oil/grease with a cloth.

⚠ Warning!

Before installing this product, read the Öhlins Owner's Manual. The shock absorber is an important part of your vehicle and will affect the stability.

Öhlins products are subject to continuous improvement and development, therefore, although these instructions include the most up-to-date information available at the time of printing, minor updates may occur.

To find the latest information contact your Öhlins distributor. Please consult your Öhlins dealer if you have any questions regarding the contents in this document.

Part no. SZSMI00_0
Issued 2010-01-31



Shock Absorber Kit for Suzuki Swift-sports (ZC31S)

SZS M100 rear

Mounting Instructions

© Öhlins Racing AB. All rights reserved. Any reprinting or unauthorized use without the written permission of Öhlins Racing AB is prohibited.

Öhlins Racing AB



www.ohlins.com



Warning!

It is advisable to have an Öhlins dealer install the shock absorber.
When installing, read your Vehicle Service Manual.



1
Raise the vehicle and put it on jack stands.

Warning!

Ensure that it is securely supported.

2
Remove the rear wheels.

3
Remove the lower and the upper attachments and remove the original shock absorbers.

Caution!

Support the lower arm with the jack before removing the damper. Otherwise, when the damper is removed, the lower arm rapidly falls.

4
Remove the spring.

5
Install the Öhlins spring on the vehicle.

6
Fit the dust boot, the washer, the std rubber bushes and the spacer according to fig ①.

7
Install the Öhlins shock absorbers on the vehicle according to fig ②.
Tighten the nylon nut to 20 Nm.

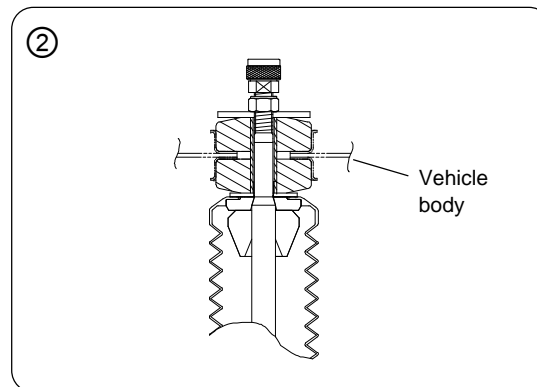
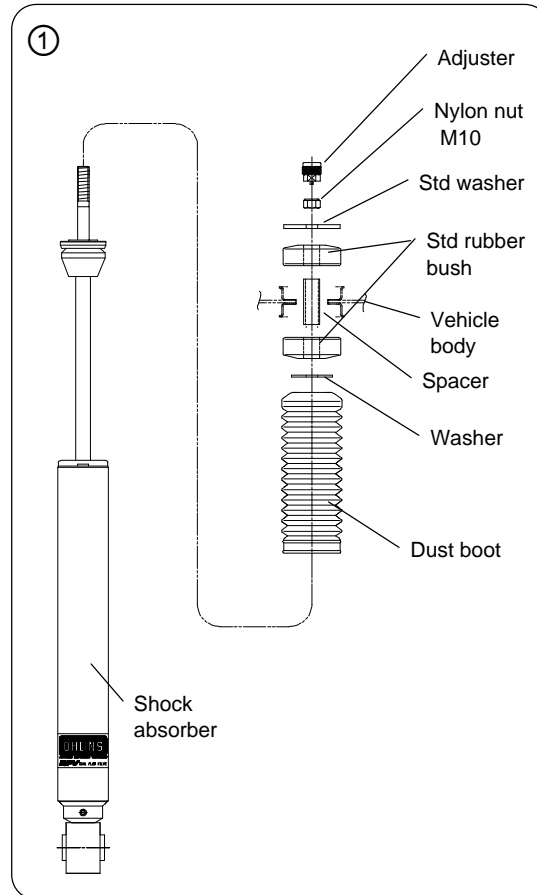

Note!

When tightening the top mount nut, the shock absorber shaft must be held in position with a 4 mm Allen key.

Note!

Make sure that all bolts are tightened to the correct torque and that nothing fouls or restricts movement of the shock absorber when it is being fully compressed or extended.

8
Make sure that all removed parts are reinstalled in the same way as they were before the installation of the Öhlins shock absorber.

3

Make a Ø40 to 50 hole in the side panel in the shown position to make the adjuster easy to operate.

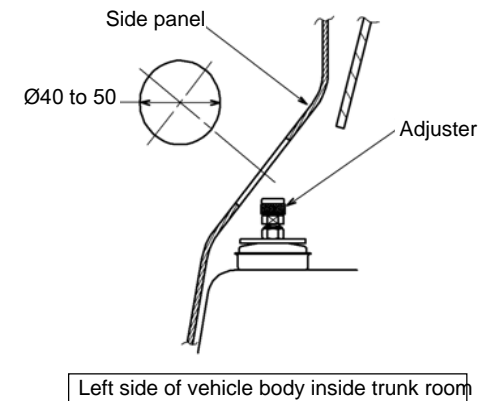

Left side of vehicle body inside trunk room