



Kit Contents			
	Description	Part No	Pcs
1	Shock absorber front	TOS 1W00/ 2W00	2
2	Dust boot	10216-02	2
3	Plastic spacer	25602-01	2
4	Spring	47000-23	2
5	Elastic spacer	25601-01	2
6	Upper spring seat	25618-39	2
7	Top pin spacer	24629-62	2
8	Flange nut	24626-04	4
9	Adjustment knob	24631-04	2
10	C-spanner	24639-01	1
11	C-spanner	24639-04	1
12	Öhlins sticker kit	10207-01	1
13	Öhlins owner manual		1

Note!

Please note that there can be small differences between your product and the images in these instructions.

Note!

Please note that during storage and transport, especially at high ambient temperature, some of the oil and grease used for assembly may leak and stain the packaging. This will not cause damage to the product, wipe off the excessive oil or grease with a cloth.

Note!

Before you install this product, check the kit contents. If anything is missing, please contact an Öhlins dealer.

Warning!

Before you install this product, read the Öhlins Owner's manual. This product is an important part of the vehicle and the vehicle stability.

Shock Absorber Kit for Toyota Yaris GR, XP210

TOS MWOOS1 front

Mounting Instructions



MOUNTING INSTRUCTIONS

⚠ Warning!

It is advisable to have an Öhlins dealer install the shock absorber.

When installing, read your Vehicle Service Manual.

1

Raise the vehicle and put it on jack stands.

⚠ Warning!

Ensure that it is securely supported.

2

Remove the front wheels.

3

Loosen the bolts for the lower strut and Anti-roll bar attachments.

⚠ Caution!

Support the wheel hubs in an appropriate way on each side of the vehicle so that the brake hoses can not be damaged.

4

Loosen the upper attachments. Remove the original struts from the car.

5

Cut the dust boot 30 mm from the lower end with a pair of scissors according to fig 1.

6

Install the dust boot (2), the plastic spacer (3), the spring (4), the elastic spacer (5), the upper spring seat (6), the top pin spacer (7), the OE top mount and the M12 flange nut (8) according to fig 2. Tighten the lock nut to 40 Nm.

👁 Note!

When tightening the top mount nut, the shock absorber shaft must be held in position with a Allen key.

Fig. 1

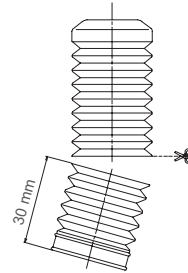
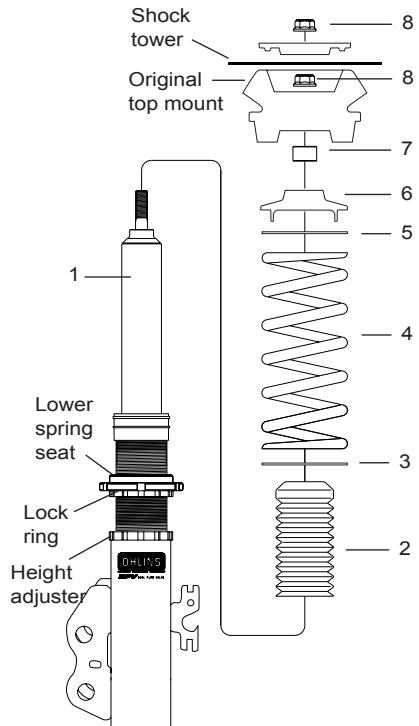

Fig. 2



MOUNTING INSTRUCTIONS

7

Position the height adjuster, lower spring seat and lock ring according to Fig 4 and tighten the spring seat with the c-spanner and the height adjuster by hand (will be torqued when mounted on the car).

8

Install the Öhlins McPherson struts to the car and fasten the upper OEM attachments with the flange nut (8).

9

Install the lower bolts and tighten to OE torque 270 Nm.

👁 **Note!**

Make sure that all bolts are tightened to the correct torque and that nothing fouls or restricts movement of the strut when it is being fully compressed or extended. Test this over the whole steering range from lock to lock.

10

With the Öhlins McPherson strut installed on the vehicle, tighten the height adjuster lock ring with the c-spanner to 120 Nm according to Fig. 3.

11

Make sure that all removed parts are reinstalled in the same way as they were before the installation of the Öhlins shock absorber.

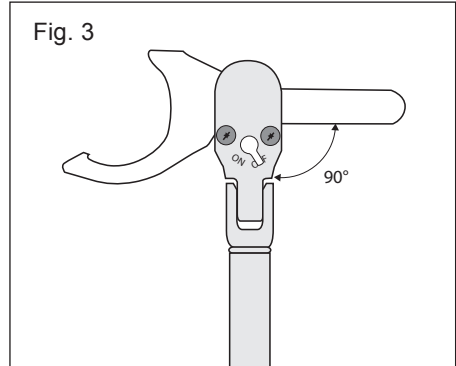

ADJUSTMENTS

⚠ Warning!

Before driving, always make sure that the basic settings made by Öhlins are according to recommended Set-up Data. Read about adjustments and setting up in the Öhlins Owner's Manual before you make any adjustments. Contact an Öhlins dealer if you have any questions about setting up the shock absorber.

The preload is 2 mm from a free length of 180 mm, giving 178 mm installed length, see fig 4.

SETUP DATA

Recommended set-up

Setting adjustment		
Track	0-7	clicks
Winding road	5-10	clicks
Street	10-20	clicks
Spring preload	2	mm
Height adjuster (X)	78	mm

Recommended spring

47000-23 (80N/mm)

The actual vehicle height

With the spring preload adjuster and height adjuster set to the recommended position, the vehicle is lowered approximately 25 mm when compared to the original suspension. Depending on car model and equipment, the spring preload and vehicle height may vary. As the preload or height adjuster is turned one rotation, the position moves 1.5 mm. Adjust the

Öhlins products are subject to continuous improvement and development, therefore, although these instructions include the most up-to-date information available at the time of printing, minor updates may occur.

© Öhlins Racing AB. All rights reserved. Any reprinting or unauthorized use without the written permission of Öhlins Racing AB is prohibited.

To find the latest information contact an Öhlins distributor. Please contact Öhlins if you have any questions regarding the contents in this document.

Öhlins Racing AB
Box 722
S-194 27 Upplands Väsby, Sweden
Phone +46 8 590 025 00
fax +46 8 590 025 80

Part no. MI_TOS MW00S1_front
Issued 2022-09-28

Fig. 4

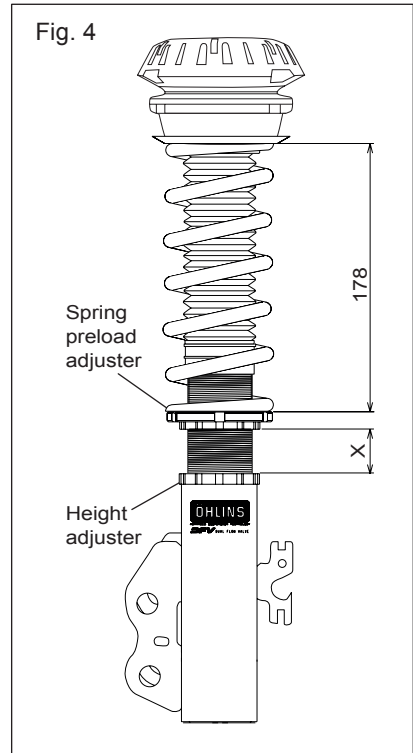

spring preload or height adjuster until you have reached your desired ride height. Make sure that the spring is always preloaded.

⚠ Warning!

The spring preload adjustment range is 0-5 mm. Never adjust the spring preload beyond 5mm preload as that may cause the spring to coil bind.



www.ohlins.com



Kit Contents			
	Description	Part No	Pcs
1	Shock absorber rear	TOS 6W00	2
2	End eye spacer	24629-63	4
3	Dust boot	10216-03	2
4	Tie rap	00231-02	4
5	Washer	24619-03	2
6	Lock nut M12	24618-04	
7	Height adjuster	24651-12	2
8	Lock nut M52	24636-03	2
9	Spring platform M52	24635-03	2
10	Plastic spacer	25602-01	2
11	Spring	47020-23	2
12	Elastic spacer	25601-04	2
13	Lower spring seat	25618-04	2

👁 Note!

Please note that there can be small differences between your product and the images in these instructions.

👁 Note!

Please note that during storage and transport, especially at high ambient temperature, some of the oil and grease used for assembly may leak and stain the packaging. This will not cause damage to the product, wipe off the excessive oil or grease with a cloth.

👁 Note!

Before you install this product, check the kit contents. If anything is missing, please contact an Öhlins dealer.

⚠ Warning!

Before you install this product, read the Öhlins Owner's manual. This product is an important part of the vehicle and the vehicle stability.

Shock Absorber Kit for Toyota Yaris GR, XP210

TOS MW00S1 rear

Mounting Instructions

MOUNTING INSTRUCTIONS

⚠ Warning!

It is advisable to have an Öhlins dealer install the shock absorber. When installing, read your Vehicle Service Manual.

1

Raise the vehicle and put it on jack stands.

⚠ Warning!

Ensure that it is securely supported.

2

Remove the rear wheels.

3

Remove the lower and the upper attachments and remove the original shock absorbers.

4

Remove the spring together with lower and upper spring seats.

5

Assemble the height adjuster (7) with the lock ring (8) and spring seat (9) according to Fig. 1 and position the spring seat according to Fig. 3 and tighten them with the c-spanners.

6

Spring assembly installation:

Mount the lower spring seat (13) in the control arm, the spring (11), the plastic spacer (10) and fit the spring preload adjuster assembly on the spring together with the rubber seat (12) according to fig 1.

Fig. 1

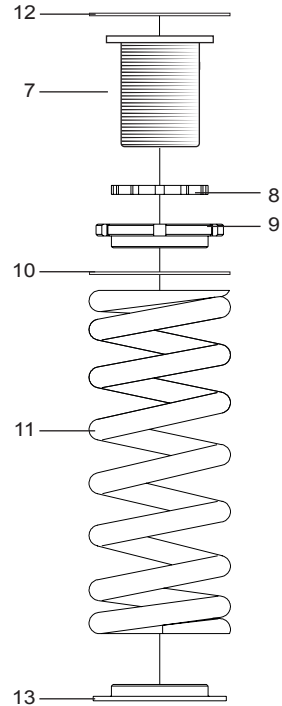

MOUNTING INSTRUCTIONS

7

Set the shock absorber length with the length adjuster and position according to fig 3, tighten the lock ring with the c-spanners. Mount the dust boot (3) with the tieraps (4) and the OE top mount with the washer (5) and lock nut (6) according to fig 2. Tighten the lock nut to 30 Nm.

8

Install the Öhlins shock absorbers on the vehicle.

9

Make sure that all removed parts are reinstalled in the same way as they were before the installation of the Öhlins shock absorber.

👁 **Note!**

Make sure that all bolts are tightened to the correct torque and that nothing fouls or restricts movement of the shock absorber when it is being fully compressed or extended.

Fig. 2

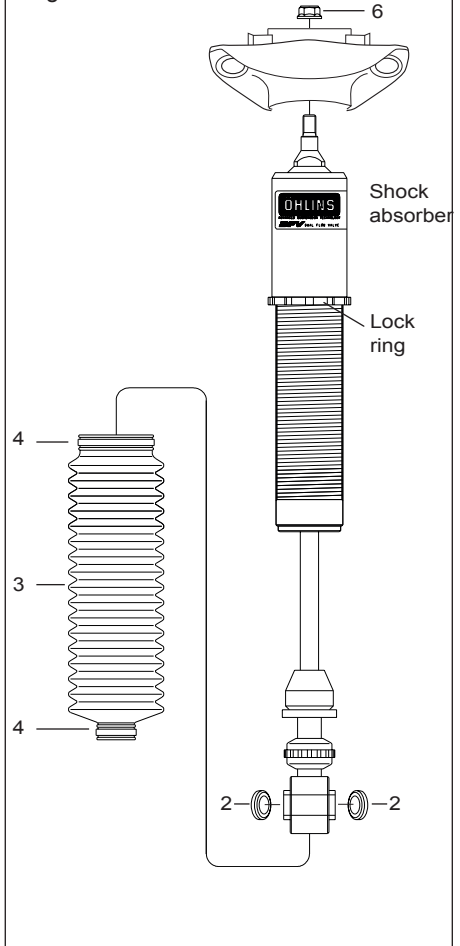

ADJUSTMENTS

⚠ Warning!

Before driving, always make sure that the basic settings made by Öhlins are according to recommended Set-up Data. Read about adjustments and setting up in the Öhlins Owner's Manual before you make any adjustments. Contact an Öhlins dealer if you have any questions about setting up the shock absorber.

SETUP DATA

Recommended set-up

Setting adjustment		
Track	0-7	clicks
Winding road	5-10	clicks
Street	10-20	clicks

Recommended spring

47020-23 (80N/mm)

Vehicle Height

With the spring preload adjuster set to the Recommended position, the vehicle is lowered approximately 25 mm when compared to the original suspension. Depending on car model and equipment, the spring preload and vehicle height may vary. Adjust the spring preload or height adjuster until you have reached your desired ride height. Make sure that the spring is always preloaded.

Fig. 3

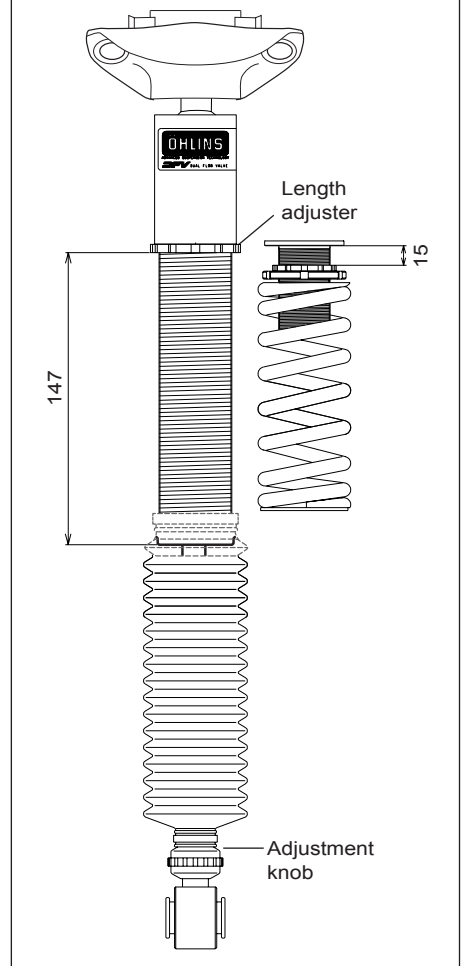

Öhlins products are subject to continuous improvement and development, therefore, although these instructions include the most up-to-date information available at the time of printing, minor updates may occur.

To find the latest information contact an Öhlins distributor. Please contact Öhlins if you have any questions regarding the contents in this document.

Part no. MI_TOS MW00S1_rear
Issued 2022-09-28

© Öhlins Racing AB. All rights reserved. Any reprinting or unauthorized use without the written permission of Öhlins Racing AB is prohibited.

Öhlins Racing AB
Box 722
S-194 27 Upplands Väsby, Sweden
Phone +46 8 590 025 00
fax +46 8 590 025 80



www.ohlins.com